

Mast Cabinet 19" two-section

DESCRIPTION:

Hermetic cabinet designed for mounting on masts and poles with a polyurethane gasket.

- Cabinet is a mechanical cover for telecommunication equipment,
- Perfect choice for installations that require frequent access to installed devices,
- Closed with hermetic locks, two at the front (main door) and two on one side of the cabinet.
- Protection IP55 and mechanical resistance IK10 ratings,
- Cable entry plugged with a multi-hole gland,
- Equipped with 19" 6U Racks mounted vertically.

Made for individual order.

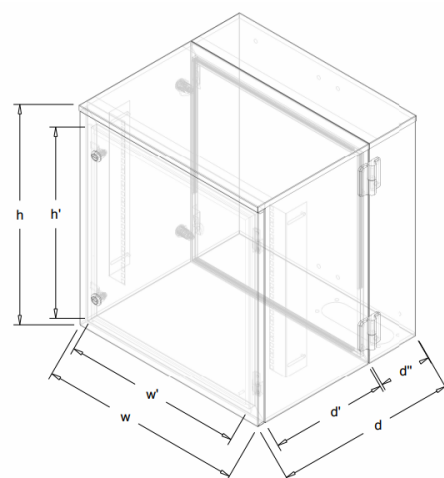

outdoor

Symbol	External dimensions (mm)			Internal dimensions (mm)		
	height (h)	width (w)	depth (d)	height (h')	width (w')	depth (d')
SM-60/55/50 10U*	601	560	504	521	494	148+313



SM-60/55/50 10U