

Mast Cabinet 19"

DESCRIPTION:

Hermetic cabinet designed for mounting on masts and poles with a polyurethane gasket.

- Made of sheet metal with Magnelis coating with a thickness of 1mm.
- Closed with two hermetic locks,
- Protection IP65 and mechanical resistance IK10 ratings (confirmed by test report No. B / 2016/233),
- Cabinet assembly (suggested due to its size) using 2 pole holders or wall mounting option,
- Rear wall stiffened in the places of mounting screws.

SM-42/55/32 19" 5U: - Standard equipped with 2 holes $\varnothing 16$ mm and 1 hole $\varnothing 24$ mm, sealed with airtight glands,

- U-bolts for mast $\varnothing 50$ mm included,
- 19" 5U rack mounts as additional equipment.

SM-50/55/41 19" 9U i SM-64/55/41 Rack 19" 12U: - Standard equipped with 6 holes $\varnothing 24$ mm located in the bottom wall, sealed with airtight glands,

- U-bolts not included,
- 19" rack mounts in standard equipment.

Additional equipment:

- 19" 1U shelf,
- 19" fiber optic distribution box,
- A set of pole holders (2 pcs).

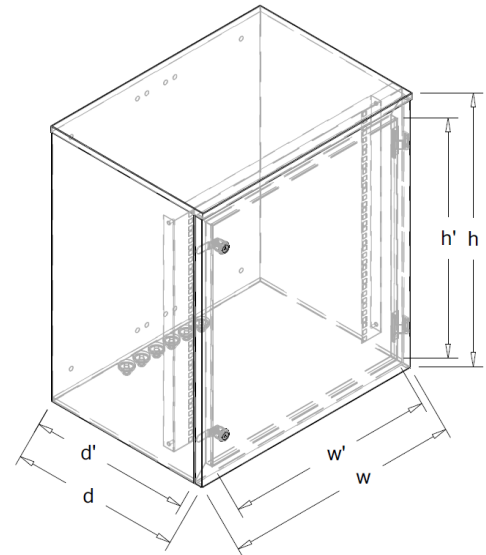

outdoor

Symbol	External dimensions (mm)			Internal dimensions (mm)		
	height (h)	width (w)	depth (d)	height (h')	width (w')	depth (d')
SM-42/55/32 19" 5U	416	558	317	332	491	290
SM-50/55/41 19" 9U	501	558	402,5	421	491	379
SM-64/55/41 19" 12U	638	558	402,5	558	491	379



SM-64/55/41 19" 12U