

## "M" Standard Cabinet

### DESCRIPTION:

Cabinet designed for wall mounting in places particularly vulnerable to devastation and burglary.

- Material: steel sheet thickness 1.5 mm.,
- The body is reinforced with steel sheet angles. 2mm.,
- Closing by 2 padlocks T-13 Barrel with a diameter of 8mm.,
- Possibility of cable entry from the top and bottom, the cabinet has 2 holes from above and from below ( $\varnothing 38 / 29$  - blinded).

### Additional equipment:

- 19" rack mounts fixed or retractable,
- Mounting plate made of magnelis / OSB sheet,
- PS 9" 1U SC Simplex / Duplex,
- Cable organizer (cable supply) on the back panel,
- Splice tray.

Possibility order with other dimensions, any number and arrangement blind holes ( $\varnothing 29$ ,  $\varnothing 38$ ,  $\varnothing 48$ ), or rectangular holes.

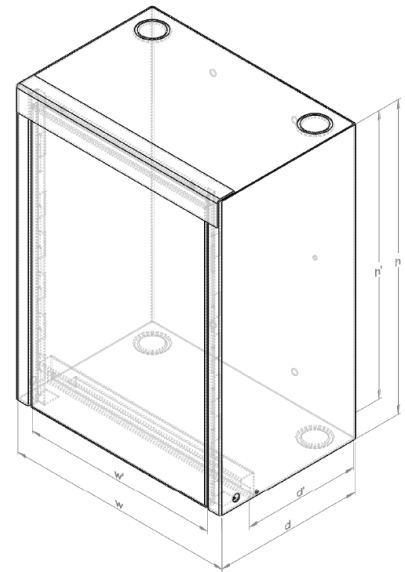

indoor

Symbol	External dimensions (mm)			Internal dimensions (mm)		
	height (h)	width (w)	depth (d)	height (h')	width (w')	depth (d')
<b>M-40/30/20 ST</b>	402	300	202	355	241	147,5
<b>M-40/40/14 ST</b>	402	400	142	335	341	87,5
<b>M-50/50/20 ST</b>	502	500	202	435	441	147,5
<b>M-50/50/30 ST</b>	502	500	302	435	441	247,5
<b>M-58/58/30 ST</b>	582	580	302	515	521	247,5



**M 40/30/20 ST**