

"M" Reinforced Cabinet

DESCRIPTION:

Cabinet designed for wall mounting in places particularly vulnerable to devastation and burglary.

- Material: steel sheet thickness 1.5 mm.,
- Special door construction reinforced with steel sheet angles. 2mm.,
- Closing by safe lock (with IMP certificate, high security according to PN-ENV 1300: 2002).
- Booking a separate key code for each client, on differently different codes (if the key is lost, it is possible to change the code without replacing the locks),
- Cabinet has 2 holes from above and from below ($\varnothing 38 / 29$ - plugged),

Z version of the cabinet has the cable stock organizer on the back panel and the L version has cable organizer and PS 1 board.

Additional equipment:

- 19" rack mounts fixed or retractable
- Mounting plate made of magnelis / OSB sheet,
- PS 9" 1U SC Simplex / Duplex.
- Cable organizer (cable supply) on the back panel,
- PSN 1.

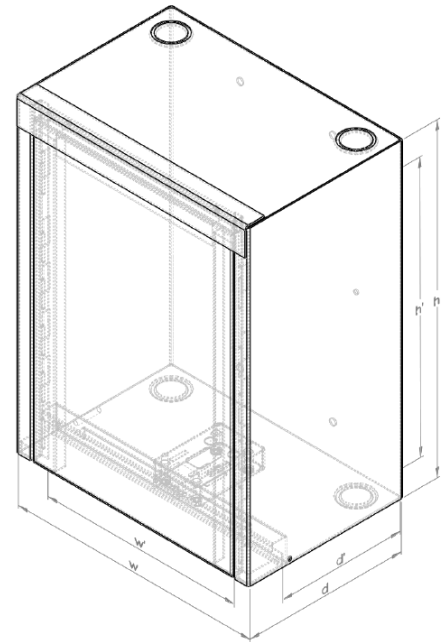

indoor

Symbol	External dimensions (mm)			Internal dimensions (mm)		
	height (h)	width (w)	depth (d)	height (h')	width (w')	depth (d')
M-40/30/20 WZM	402	300	202	355	241	147,5
M-50/50/20 WZM	502	500	202	435	441	147,5
M-58/58/30 WZM	582	580	302	515	521	247,5
M-70/58/30 WZM	702	580	302	635	521	247,5
M-70/58/30 WZM L	702	580	302	591	521	247,5
M-70/58/30 WZM Z	702	580	302	635	521	247,5



M 40/30/20 WZM