

## Fiber-Optic Distribution Box - 44J

**DESCRIPTION:**

Two-access cabinet (operator part separated from the client switching panel), equipped with a double door system.

- Material: sheet steel 1mm thick,
- Closing by 2 cylinder locks with one or two different key code,- 2 blind holes to knock out Ø29 / 38 on the top and bottom of the cabinet,
- As standard 22 holes for SC Duplex fiber optic adapters, screw for attaching a fiber optic remote control, cable organizers,
- The possibility of mounting optical couplers (splitters) and trays for optical fiber splices,
- Possibility to insert linear cables from above and below.

On request it is possible to make other cable holes and other holes for fiber optic adapters.

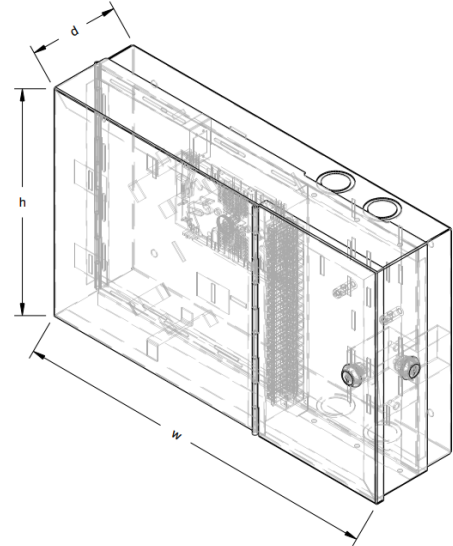

indoor

Symbol	external dimmensions (mm)		
	height	width	depth
<b>SRS-28/45/12 44J SC DX</b>	281	455	116



**SRS 28/45/12 44J DX**